

# REHA Shift™

Positioning chair



[www.akces-med.com](http://www.akces-med.com)

User manual



**⚠ ATTENTION!**

Manufacturer takes responsibility for proper usage of the device only when the product was purchased from qualified Akces-MED Ltd. employee or at specialized medical store!

**Akces-MED Ltd.** reserve the right to introduce technical and trading changes in the content of the instruction without warning.



Product marked with the CE sign is Class I medical device, of rule 1, consistent with the requirements of Regulation (EU) 2017/745 of the European Parliament and of the Council of 5 April 2017 on medical devices.



Akces-MED Ltd. Company introduced quality management system ISO 13485 regarding production, sales and service.  
The system is certified by SGS.

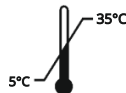

# Contents

---

Introduction.....	4
1. The purpose of user manual.....	5
2. Indications and contraindications for use.....	5
3. General characteristic of the chair.....	7
4. Size table.....	8
5. How to use the chair.....	9
5.1 Unfolding the chair.....	9
5.2 Folding the chair.....	10
5.3 Adjustable backrest.....	11
5.4 Adjustable headrest.....	11
5.5 Narrowing cushions stabilizing pelvic and trunk.....	12
5.6 Pelvic belt.....	12
5.7 Abduction block.....	13
5.8 Adjustable footrest.....	13
5.9 Safety rail.....	14
5.10 Swivel wheels with independent brakes.....	15
6. The use of the chair.....	16
6.1 Preparation of the user.....	16
6.2 Preparation of the chair.....	16
6.3 Sitting position.....	17
6.4 How to use vests.....	18
7. Safety rules.....	21
8. Terms of warranty.....	23
9. Maintenance and cleaning.....	23
10. Labelling.....	27

# Introduction

---

RehaShift™ is an innovative rehabilitation chair designed for children with musculoskeletal dysfunctions. Its main advantages include compact dimensions and the ability to provide stabilization to the user in a comfortable home environment. RehaShift™ is not only a therapeutic tool, but also a practical product that can be used as a chair for a table or desk.

The chair offers adjustable backrest, seat, and an innovative footrest with smooth and stepless adjustment, allowing full customization to the user's individual needs. The hip belt supports stabilization, while adjustable cushions and side supports provide excellent body stabilization, ensuring lateral stability.

RehaShift™ is equipped with a practical home base that can be folded, making the seat easy to store and ready for use in any location. This compact solution allows the chair to be used in various home spaces, providing comfort and safety to the user. RehaShift™ serves as perfect support in daily life, adapting to the needs of children with various rehabilitation requirements.

Remember to read this user manual carefully. You will find not only useful information but also guidelines regarding safe and effective use of the product.

If you have any questions or remarks, do not hesitate to contact with us:

Medical consultant: mobile +48 516 183 883

Akces-MED Ltd.: ph. +48 17 864 04 70

e-mail: [export@akces-med.com](mailto:export@akces-med.com)

## ATTENTION!

Before using the product, user is obliged to familiarize himself/herself with user manual.

Remember that complying with guidelines is highly important. It assures safety and extends durability as well as aesthetics of the device.

# 1. The purpose of user manual

---

## ATTENTION!

The instruction manual contains basic information necessary to properly prepare the device before use, use the device, maintain and clean the device.

This user manual should be kept in an easily accessible place. The manual is intended for people who look after disabled users, as well as for doctors and physiotherapists handling the device.

Before using the Reha Shift™ for the first time, the user (or caregiver) is obliged to familiarize himself/herself with the user manual.

## 2. Indications and contraindications for use

---

These medical devices are intended for people with orthopedic, neurological and cardiological diseases and for people after surgery, with musculoskeletal dysfunctions, who have not acquired the ability to sit independently or who have difficulties in adopting and maintaining the sitting position.

Both for flaccid people with reduced muscle tone and for people with spasticity. The device can also be really useful for people who require long-term relief of one or both lower limbs. It is an irreplaceable aid in the rehabilitation process, both in terms of movement and social integration. The device is great help during everyday activities such as rehabilitation but also during playing, studying or having meals. The selection of the appropriate size of the device depends on medical indications and anatomical parameters, regardless of the age of the user.

### **The device is recommended for people in the following cases:**

- Cerebral palsy – various types and forms.
- Brain and spinal cord injuries with lower limbs paralysis and weakness, balance and motor coordination disorders with different etiology.
- Demyelinating disease (e.g. multiple sclerosis - SM).
- Meningocele.
- Muscles diseases with weakness and paralysis (dystrophy, myasthenia gravis, myositis).
- Genetic disorders.
- Degeneration and neurological diseases.
- Other condition connected with muscles weakness, paralysis and musculoskeletal disorders.
- After head and spinal cord injuries and spine trauma with paralysis and paresis.

## 2. Indications and contraindications for use

---

### **Contraindications:**

- Critical condition of the user.
- Paralysis.
- Deep sedation.
- Unstable fractures with specific orthopedic recommendations, including spine fractures.
- Untreated deep vein thrombosis.
- Hemodynamic instability.
- Identified brain dysfunction when sitting upright.
- Severe arthritis of the cervical spine.
- Pulmonary embolism.
- Recent myocardial infarction in the last 24 hours.
- Fresh postoperative wounds or non-healing wounds in the back area, pelvic girdle area, hip joints and thighs.
- Users with mental disorders should not be left in the device without the supervision of a caregiver.

### 3. General characteristic of the chair



#### **i** INFORMATION!

Accessories available for this product can be found on the [akces-med.com](http://akces-med.com) website under the product page.

## 4. Size table

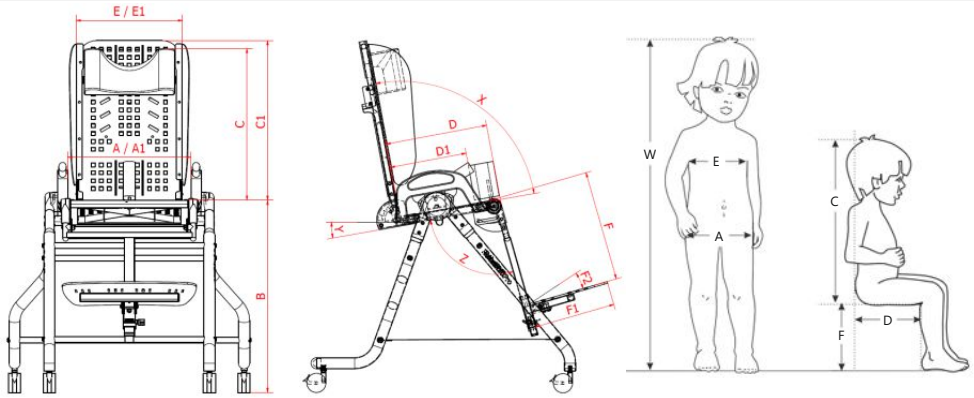

Symbol	Measurement	Unit	Size 1
W	indicative user height *	[cm]	110
A	seat width with narrowing cushions	[cm]	18
A <sub>1</sub>	seat width	[cm]	28
B	seat height	[cm]	53
C	headrest height	[cm]	46 - 51
C <sub>1</sub>	backrest height	[cm]	52
D	seat depth	[cm]	28
D <sub>1</sub>	seat depth to the abduction block	[cm]	13 - 22
E	backrest width with narrowing cushions	[cm]	19
E <sub>1</sub>	backrest width	[cm]	29
F	footrest length	[cm]	15 - 32
F <sub>1</sub>	footer length	[cm]	23
F <sub>2</sub>	footplate tilt angle	[°]	-5 - 10
X	backrest tilt angle	[°]	90 - 180
Y	seat tilt angle	[°]	10
Z	footrest tilt angle	[°]	90 - 180
	max. user weight	[kg]	40

### Product dimensions and weight

	Unit	Size1
width	[cm]	70
length	[cm]	78
height	[cm]	101
width after folding	[cm]	70
length after folding	[cm]	118
height after folding	[cm]	28
weight	[kg]	13

**Note:** Measurement tolerance range is +/- 1 cm / ½ in.

\* This measurement cannot be the main parameter while choosing the product size.



## 5. How to use the chair

### 5.1 Unfolding the chair



#### **⚠ ATTENTION!**

The base has a safety strap - it is necessary to inspect its condition, and if you notice abrasions, cracks, rips, stop using the product and contact the manufacturer or authorized dealer from whom the product was purchased for replacement.



#### **⚠ ATTENTION!**

When assembling the seat, a characteristic "CLICK" can be heard.

Pay attention to the direction of the seat installation - the extended bend of the frame tells the side where the backrest should be.

Before using the product, check the correct installation of the seat on the frame.

# 5. How to use the chair

## 5.2 Folding the chair



## 5. How to use the chair

### 5.3 Adjustable backrest



#### ATTENTION!

When adjusting the backrest, make sure that the locking pins are locked at the same height. Before using the product, check the correct locking of the backrest at the selected position.

### 5.4 Adjustable headrest



#### INFORMATION!

The headrest has the option of mounting it at two heights. When mounting, tie the strings behind the seat back.

## 5. How to use the chair

### 5.5 Narrowing cushions stabilizing pelvic and trunk



### 5.6 Pelvic belt

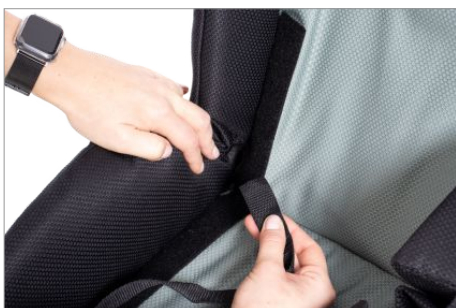

1.



2.

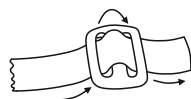

3.



4.



## 5. How to use the chair

### 5.6 Pelvic belt



### 5.7 Abduction block

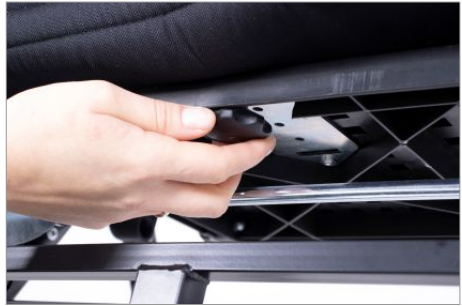

### 5.8 Adjustable footrest



## 5. How to use the chair

### 5.8 Adjustable footrest



#### INFORMATION!

Use the screws under the footrest platform to adjust the tilt of the platform.

#### REQUIRED TOOLS

allen key 4 mm

#### ATTENTION!

When putting the user in and getting out of the seat, make sure not to stand on the footrest!

### 5.9 Safety rail



## 5. How to use the chair

### 5.9 Safety rail

#### **i** INFORMATION!

The safety rail can be removed on one side, making it easy to put the user in and out of the product.



### 5.10 Swivel wheels with independent brakes



BRAKE UNLOCKED



ACTIVE BRAKE

#### **!** ATTENTION!

Putting the user in and out of the product should be done with the brakes active.

## 6. The use of the chair

---

### ATTENTION!

Before using the product, user is obliged to familiarize himself/herself with user manual.

Do not forget to prepare both product as well as user before using the device.

### 6.1 Preparation of the user

Before using the product, it is essential to make sure that:

- user's outfit is light and comfortable sporty clothes are advisable,
- shoes should be comfortable and, moreover, they should stabilize ankle,
- due to hygienic reason and to avoid abrasion it is advisable for the user to always wear clothes when using the device, skin must not be naked especially in places of regular contact with upholstery,
- drains, bags, catheters etc. if applied, have to be secured to function properly and not to disturb during using the product,
- if it is necessary for a user to wear orthopedic supply (collar, corset, orthosis, shoes) if it is recommended by doctor.

### ATTENTION!

Outfit should protect user's skin from direct contact with upholstery as well as other parts of equipment.

Only doctor can make a decision concerning using any kind of orthopedic supply!

### 6.2 Preparation of the chair

1. Before use it is necessary to:

- unfold the device,
- place the device on even ground,
- make sure that all parts are serviceable, correctly mounted and stable,
- block brakes,
- adjust the device to user's measurements,
- undo vest so as to place easily the user in the device,
- place user in the device,
- fasten all elements which stabilize user e.g. vest, trunk belts, feet stabilizing belts etc.,
- mount additional equipment e.g. tray.

2. In case of user who have problem with bladder, it is necessary to put special cloth on seat. This cloth can be purchased in pharmacy or medical shops.



## 6. The use of the chair

### 6.2 Preparation of the chair

#### ATTENTION!

Before the product is used, it is highly necessary to make sure that all belts as well as safety equipment are correctly fastened as well as adjusted. What is more, check if they do not become undone due to the pressure and, moreover, make sure that clampings from adjustable elements are firmly tightened!

Equipment works correctly only when the device is adjusted according to user's height as well as weight. Remember to take all these measurements into account while purchasing the product.

Correct adjustment is the most important due to the fact that only then the product is safe.

It is forbidden to force user to keep specific position because he/she will feel uncomfortable and it may lead to wrong posture.

### 6.3 Sitting position

The first use of the positioning chair usually takes place at a rehabilitation, neurology, neurosurgery or orthopedics center. It is especially important to correctly adjust each element of the chair to the user regarding their condition and taking into account existing contractures and deformations. The first use of the chair at home should be done with the help of qualified staff (physiotherapist, health nurse, properly prepared family members) after having read the instruction manual.

#### ATTENTION!

Incorrect chair adjustment can lead to such side effects as fainting, body deformities, joint overload, etc.

If the abovementioned symptoms occur, stop using the chair immediately, take the user out of the chair and lay them down. If the undesirable symptoms persist, contact a physician immediately. If the symptoms have disappeared, inform the attending physician about this fact in order to make a decision about the further rehabilitation process.

The decision to use the positioning chair must always be made by the attending physician.

Adjusting the chair to the user should only be done by people who have been properly trained and have read the instruction manual.

## 6. The use of the chair

### 6.4 How to use vests

#### ATTENTION!

The vest provides posture support for wheelchair users as well as users sitting in positioning chairs or other rehabilitation seats. When properly used, the vest allows the user to adopt the correct sitting position for a longer period of time. The design and shape of the vest make it possible for the user to be free to move their upper limbs within the constraints of the user

**If the vest is not used properly, it can pose a serious threat to the health and life of the user!**

Possible threats incident to the use of the vest:

- 1) If the lower vest straps are fastened too loosely, there is a risk that the vest will move upwards to the user's neck, making it difficult to breathe - always check the tension of the straps and set them in such a way that the lower edge of the vest is located near the lower abdomen of the user.
- 2) In a situation when the user slips off the seat, the upper edge of the vest covers the user's neck and blocks the trachea, making it difficult to breathe - it is therefore necessary to ALWAYS use the accessories stabilizing the user's pelvis, such as a pelvic belt, thigh abduction belts or an abduction block.
- 3) There is a risk that the upper straps of the vest will press the user's neck, blocking the trachea and making it difficult to breathe. This might happen if the user's body is improperly secured in the seat or stroller - it is then necessary to use the optional accessories of these devices and stabilize the user's body using the lateral supports. If there is no possibility to use such accessories with the device and the user's body cannot be properly stabilized, the device should be replaced with the one having such an option.
- 4) The vest is fastened too tightly to the backrest and as a result the user cannot breathe easily – in this case the vest should be loosened in such a way that it is possible for the caregiver to insert a straightened hand between the vest and the user's body. If, however, we want to stabilize the user's body properly, we should use a dynamic e.g. a FlexPoint® vest, which does not cause the breathing difficulty for the user.

Instructions for the proper use of the vest:

- 1) Make sure that the user is sitting in the best possible position:
  - in the middle of the seat,
  - deeply in the seat in such a way that the user's lumbar spine rests against the backrest.
- 2) Secure the user's pelvis.
- 3) Make sure that the side supports of the device, if used, are set in the correct position. It is required that the users with the poor trunk control use the side supports. The side supports limit the lateral movements of the user's body, which could lead to the compression of the vest straps on the neck of the user.

## 6. The use of the chair

### 6.4 How to use vests

- 4) Secure the vest:
  - fasten and adjust the lower straps of the vest, so that the lower edge of the vest is located near the lower abdomen of the user,
  - fasten the horizontal strap of the vest (if present),
  - fasten the shoulder straps of the vest,
  - check if the buckles of the vest do not open under pressure.
- 5) Check the user's position:
  - make sure that the vest cannot move by itself towards the user's neck,
  - make sure that you can insert a straightened hand between the vest and the user's body.

To prevent injuries and to minimize the risks associated with the use of the vest, the following rules should be followed:

- 1) The position of the vest **MUST** be checked each time after putting the user in the seat.
- 2) Special attention should be paid to protecting the user from falling forward, slipping off the seat or lifting the pelvis. The vest **MUST** be used with the accessories which will secure the user's pelvis at all times (e.g. the pelvic belt, thigh abduction belts or the abduction block). The use of the vest cannot be considered separately but as a part of a general posture support system including supports such as pelvic belts, foot support, torso stabilization, thigh abduction belts, tilt-in-space position and reclining backrest.
- 3) Special attention should be paid to ensuring that the entire foot of the user has stable support. If the device is not equipped with a foot support, the user's feet must rest firmly against the ground.
- 4) It should be remembered that any change of the inclination angle of the backrest, seat, foot support or tilt-in-space function might affect the effectiveness of the belts and supports!
- 5) Special attention should be paid to the use of stabilization elements or side supports. If the user has poor trunk control, the side supports will limit the lateral movements, which could lead to the compression of the vest straps on the neck of the user.
- 6) The mounting of the vest and adjusting it to the user can only be carried out by a suitably trained person, who is familiar with the instructions for the use of the vest and the rules of its safe use.
- 7) Do not make any repairs or modifications to the vest on your own. In order to repair or replace any part of the vest, please contact the manufacturer.
- 8) Do not use a damaged or incomplete vest, as this poses a serious threat to the health and life of the user!
- 9) Do not leave the user in the device unattended!
- 10) The correctness of the use of the vest should be particularly controlled in accordance with the recommendations in case of children, users with impaired memory or mentally ill.
- 11) Make sure that all people taking care of the user are familiar with the rules of the safe use of the vest.

## 6. The use of the chair

### 6.4 How to use vests

How to care for the vest:

The vest works effectively only if kept clean and maintained in accordance with the manufacturer's instructions. Before each use of the vest, check whether:

- 1) The vest straps are not frayed or worn. If so, have them exchanged for new ones.
- 2) The vest straps are not attached to the wheels of the device.
- 3) The buckles are not damaged. If so, have them exchanged for new ones.
- 4) The velcro fastening holds firmly. If not, remove any dirt or hair from the velcro, or have it replaced with a new one.
- 5) There have been no changes in the user's height or weight from the moment the vest was adjusted to the user.
- 6) The shoulder straps of the vest are adjusted so that they are not too loose or too tight.
- 7) The vest should be cleaned regularly with the use of warm soapy water and dried out of the direct sunlight and other sources of heat. The vest must always be dry before usage.

If you have any doubts or questions about the use of the vest, please contact your doctor or physiotherapist.

## 7. Safety rules

---

### ATTENTION!

Reha Shift™ positioning chair has to be used with compliance to guidelines included in this user manual.

Do not forget to prepare both product as well as user before using the device.

It is highly important to consult either doctor or physiotherapist in order to make right decision concerning the choice of chair and its size. It is also essential to familiarize with the guidelines described in user manual before using the device.

1) Before use it is necessary to:

- make sure that there are no damages or different faults which could endanger user's life,
- check if all parts are working and are correctly mounted and, moreover, check if they are not broken,
- check if all screws, knobs and all glued, sewed or tapped parts are tightened,
- check if brakes are operating correctly,
- check if buckles are operating correctly,
- always use safety belts, Velcro tapes should overlap min. 8cm,
- adjust the device according to user's measurements and needs e.g. the adjustment of pelottes, bfootplate etc.,
- make sure that all movable parts and knobs for adjustments are stable and locked,
- secure user with the aid of elements such as vest, foot stabilizing belts, pelottes, abduction block, headrest. It is highly important to secure user because it safeguards him/her from falling out. If abduction contracture occurs, it is recommended to use abduction block in order to prevent ulcers between knees.

2. It is forbidden to use chair for different purposes that it is intended to.

3. It is forbidden to use chair when it is damaged or any part is missing.

4. It is forbidden to leave the user unattended.

5. Chair should be used only when there is someone who is trained and knowledgeable.

6. It is forbidden to leave chair and the user on unstable ground unattended, even if the brake is engaged.

7. It is forbidden to either go up or down the stairs; it doesn't matter if the user is placed in the device or not.

8. It's important to make sure that user doesn't stand on footer during either getting into or getting out the chair.

9. It is important to engage brake during getting into and getting out the chair.

10. Make sure that all limbs are not close to spokes or other adjustable elements.

11. Please pay your attention when approaching to sources of fire or sources of high temperature during using the device. Moreover, chair shouldn't be stored in rooms with high humidity.

## 7. Safety rules

12. Secure chair during transportation in order to avoid any possible damages. Manufacturer doesn't take responsibility for damages which appeared due to improper preparation of the device during transportation.
13. Before using the chair, remove all paper and plastic packaging. The packaging is not a toy! Keep away from children and animals.

### ATTENTION!

Incorrect product adjustment can lead to such side effects as fainting, body deformities, joint overload, etc. If the abovementioned symptoms occur, stop using the product immediately, take the user out of the product and lay them down. If the undesirable symptoms persist, contact a physician immediately. If the symptoms have disappeared, inform the attending physician about this fact in order to make a decision about the further rehabilitation process.

Serious incidents involving this device should be reported both to manufacturer and to the competent authority in your country.

It is forbidden to place the patient in the device while being in car, bus or train.

The product contains small parts which children may swallow.

Do not use a product that has any signs of damage, tearing or wear. Only an undamaged product and proper use guarantee its right and safe working. If the product is damaged, discontinue use and contact the manufacturer.

Under no circumstances should an unqualified person repair or alter the product and its construction, as the health and safety of the user depend on it as well as it will lead to the loss of warranty.

The weight of user should not be bigger than maximal weight described on page 8 where you will find information regarding this issue.

## 8. Terms of warranty

---

- Akces-MED Ltd. sells products free from manufacturing defects or faults.
- Manufacturer gives the purchaser 24-month guarantee from the date of purchase. All defects revealed during warranty period will be repaired free of charge.
- All defects which appear after warranty period can be repaired only when the user will pay for it. This rule doesn't apply to refunded products - user can ask National Health Refund for refund.
- The chair is covered by a 36-month warranty on the territory of Canada – the details of the rights resulting from the extended warranty are regulated by the warranty card.
- Manufacturer claims that the product can be used for 48-months. User can use this product after this period only when he/she will send the device to manufacturer so as to service it. Next, manufacturer determines again how long the product can be used and, moreover, the date of the next service will be determined.
- If product is damaged, please contact our dealer or the Akces-MED Ltd. Customer Service Department (ph. +48 17 864 04 77, e-mail: [export@akces-med.com](mailto:export@akces-med.com)).

## 9. Maintenance and cleaning

---

The positioning chair Reha Shift™ which is a medical device, should always be kept clean and should be used in accordance with the manufacturer's instructions. The chair should be kept in a clean, dry and ventilated room. Maintenance and cleaning must be done at least once a month. Periodic cleaning and maintenance of the chair is essential to keep its proper functioning and safety.

Recommendations for cleaning the upholstery and other elements of the seat:

1. Wash with warm water using a soft cloth and mild cleaners.
2. Make sure the cloth is not too wet, as this may enlarge the stain and damage the upholstery or foam inside the upholstery.
3. Remember to remove excess moisture from the upholstery before the next cleaning.
4. After cleaning the stains, the upholstery should be rinsed with lukewarm water and dried with a clean cloth.
5. You must not soak the upholstery.
6. The upholstery must not get wet during cleaning.
7. Do not use hard brushes for cleaning the upholstery.
8. Do not clean the upholstery with strong chemicals, e.g. solvents or chlorine-based caustics.
9. Do not clean, replace any elements or maintain the chair during use.
10. Metal and plastic elements should be cleaned by hand with suitable cleaners, after having read the recommendations of the manufacturer of the given cleaner.

## 9. Maintenance and cleaning

11. It is possible to disinfect metal, plastic, wooden and upholstery elements of the product with a generally available disinfectant. In order to disinfect the selected element, spray its surface with a disinfectant generally available on the market and wipe with a dry, clean cloth. After disinfection, wait until the element is completely dry, especially in the case of upholstery. Before using the disinfectant, first check in an invisible place whether the product will not discolor or damage the disinfected surface.

### **ATTENTION!**

Remember that upholstery has to be always dry before using!

The manufacturer of the chair, Akces-MED Ltd., is not responsible for any damages caused by using unsuitable cleaners.

Before using it is necessary to:

- clean wheels,
- check if base as well as wheels are correctly mounted, check if brake stops turning wheel,
- check if wheelchair construction is free of breaks or any kinds of deformities,
- check if all movable parts are working and all screws, nuts, knobs etc. are correctly tightened,
- check if belts, vests, trunk belts, feet stabilizing belts etc are not frayed; check if buckles and clamps work correctly.

### **ATTENTION!**

Manufacturer takes responsibility only for hidden faults or damages which appeared despite the fact that user complied with the guidelines.

In case of any damages, it is essential to contact the person who sold you the product.





# 9. Maintenance and cleaning

## TECHNICAL INSPECTION

Technical inspections should be performed regularly. Before servicing, the product should be thoroughly cleaned to reveal any hidden damage.

Frequency	What should be checked?	What should be done?	Remarks
Before each use.	General condition of the product.	<p>Check:</p> <ul style="list-style-type: none"> <li>the entire product for any visible damage, cracks or mechanical defects,</li> <li>if the product complete,</li> <li>if all bolts, screws, knobs, nuts and other elements of the construction are complete and tightened.</li> </ul>	In case of any damage or defects, discontinue the use of the product and contact your Supplier/Distributor or the Manufacturer.
	Wheels and brakes	<p>Check:</p> <ul style="list-style-type: none"> <li>if the wheels are properly mounted and if they are not damaged,</li> <li>if the brake is blocking the spinning wheel,</li> <li>if the wheels are not dirty. If necessary, clean the wheels.</li> </ul>	In case of any damage or defects, discontinue the use of the product and contact your Supplier/Distributor or the Manufacturer.
	Fastening of the construction elements.	<p>Check all the mechanisms of the product and its moving parts. Check in particular:</p> <ul style="list-style-type: none"> <li>if the seat is properly mounted (if applicable),</li> <li>if the wheels are properly mounted (if applicable),</li> <li>if the elements securing the user are properly mounted and if they work well (if applicable),</li> <li>if all the moving parts are complete, work properly, do not jam,</li> <li>if the adjustment mechanisms of the following elements work properly (if applicable): headrest, backrest, seat, abduction block, armrests, footrests.</li> </ul>	In case of any damage or defects, discontinue the use of the product and contact your Supplier/Distributor or the Manufacturer.
	Upholstery elements.	<p>Check:</p> <ul style="list-style-type: none"> <li>if there is any damage, tears, rips, loose seams or deformations on the upholstery elements</li> <li>if the stabilizing straps, vests or safety belts are not frayed or twisted and if the buckles work properly,</li> <li>if the stabilizing straps, vests or safety belts work correctly and do not unfasten under pressure or when pulled.</li> </ul>	In case of any damage or defects, discontinue the use of the product and contact your Supplier/Distributor or the Manufacturer.
Once a week.	Product cleaning.	If the frame and upholstery get dirty (dusty, muddy, etc.) during everyday use, wipe them with a damp cloth without detergents. Remove dirt (e.g. hair, food remains, etc.) from the moving parts of the product.	The product should be cleaned when necessary, but at least once a week. Do not use any chlorine based cleaners or methylated spirit. Before using the product, check if the upholstery is dry.

# 9. Maintenance and cleaning

## TECHNICAL INSPECTION

Technical inspections should be performed regularly. Before servicing, the product should be thoroughly cleaned to reveal any hidden damage.

Frequency	What should be checked?	What should be done?	Remarks
Once a month.	Wheel axles, quick connectors (if applicable).	<p>Check:</p> <ul style="list-style-type: none"> <li>if the wheels are rolling and if they are not loose. To maintain the wheels, apply a small amount of a preservative-lubricant between the axle and the wheel hub. Check if you can easily remove and attach the wheels.</li> </ul>	<p>Clean the wheels when dirty.</p> <p>In case of any damage or defects, discontinue the use of the product and contact your Supplier/Distributor or the Manufacturer.</p>
	Product construction connectors (welding, threading, soldering).	<p>Check:</p> <ul style="list-style-type: none"> <li>the condition of the product frame in the places of joining (welds, threads, soldering).</li> </ul>	<p>In case of any damage or defects, discontinue the use of the product and contact your Supplier/Distributor or the Manufacturer.</p>
	Tires/innertubes (if applicable).	<p>Check:</p> <ul style="list-style-type: none"> <li>tire wear condition. Check for visible damage. Check tire pressure (if applicable).</li> </ul>	<p>If the tire pressure is too low, inflate them to the correct level.</p> <p>In case of any damage or defects, discontinue the use of the product and contact your Supplier/Distributor or the Manufacturer.</p>
Once every 6 months.	Construction moving parts.	<p>Check:</p> <ul style="list-style-type: none"> <li>if the moving parts of the construction have not been damaged. Maintain them using a proper cleaning agent.</li> </ul>	<p>In case of any damage or defects, discontinue the use of the product and contact your Supplier/Distributor or the Manufacturer.</p>
	Product labeling	<p>Check:</p> <ul style="list-style-type: none"> <li>if the marking and labels are readable.</li> </ul>	<p>In case of any damage or defects, discontinue the use of the product and contact your Supplier/Distributor or the Manufacturer.</p>
After the life time of the product finishes.	Detailed product check.	Check the product	<p>The manufacturer specifies the life time of the product, which is given in the user manual. After the given period, the user may use the product only if it is sent back to the manufacturer to be checked first. After that, the manufacturer will re-define the life time of the product and the date of the next check.</p>

# 10. Labelling

**CE** Declaration that the product meets the essential requirements

**REF** Catalog number

**SN** Serial number

 Please read the manual instructions before use

 You need to take special precautions!

 Manufacturer

 Production date

 The product does not contain latex

 Store in a dry place

 Prohibition of use without fastened safety belts

 Protect from sunlight

 Storage temperature limitation

 Relative humidity storage

 Dry vertically

 Do not chlorinate

 Do not iron

 Do not dryclean

 Do not bleach

 Cafereful! Delicate content!

 It is forbidden to either go up or down the stair. It does not matter if the user is placed in the device or not

 Prohibition to leave the user without care during use of the product

 You need to read the additional information

**PRESS** You need to press the button shown in the photo

 You need to ude the tools indicated in the assembly description

**MD** Medical device

## Sample data plate

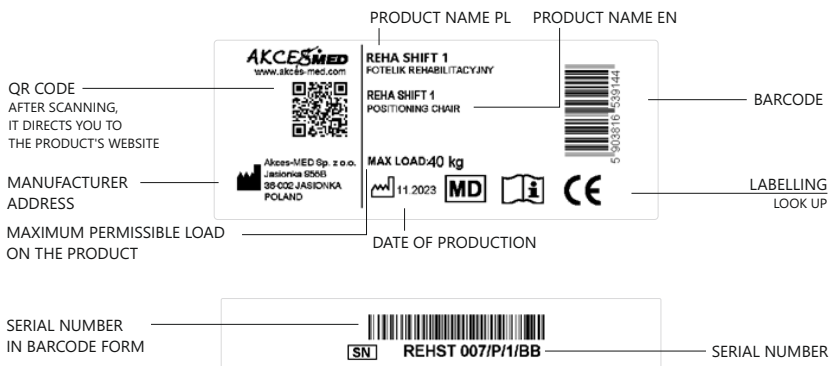

## MANUFACTURER



**Akces-MED Sp. z o.o.**

Jasionka 955 B  
36-002 Jasionka  
tel. +48 17 864 04 77  
e-mail: [export@akces-med.com](mailto:export@akces-med.com)  
BDO: 000031619

Authorised Dealer